

 SONOR

SQ² · 01 · 08

 SONOR[®]

SQ²
DRUM SYSTEM

WWW.SQ2-DRUMSYSTEM.COM

WWW.SONOR.COM



SQ² DRUM SYSTEM

YOUR ULTIMATE CUSTOM DRUM KIT!

Unique handcrafted custom made instruments. Built to your exacting specifications!

The SQ² Story – Over 130 years of design and drum innovations ... Precision German Engineering! ... Made in Germany! ... unparralled tone and performance! ... hand built craftsmanship! ... distinctively innovative!	04
The SQ² Distinction – Features & Benefits AcoustiGate! ... Advanced Projection System! ... TuneSafe!	06
The SQ² Revolution – The Configurator System online Configurator! ... virtually limitless combinations & possibilities! ... build the virtual kit of your dreams in minutes! ... immediate, direct international online pricing! ... unique order & individualized identification system!	08
The SQ² Experiences – Let yourself be inspired Black & White Beauty ... Walnut Dreams ... Golden Pearl ... The Tiger Within ... Intergalactic Metal Blaster ... Just Noble	12
The SQ² Hardware – Essential elements State of the Art Giant Step Pedals! ... uncompromisingly stable 600 Series Hardware! ... ultimately flexible Basic Arm System!	22



THE SQ² STORY

OVER 130 YEARS OF DESIGN AND DRUM INNOVATIONS

- 01 | First Single Bass Drum Pedal world-wide – 1900
- 02 | First Tom Tom with wood hoops – 1925
- 03 | First Double Bass Drum Pedal (Duplex) world-wide – 1910
- 04 | Single Bass Drum Pedal and Hi-Hat – 1935
- 05 | Snare Drum with multi 3-way strainer – 1930
- 06 | First Drum kit with Concert Toms – 1955
- 07 | Introduction of “Vertical Grain” Drums, Sonor Champion Series Drum kit in Rosewood – 1973

- 08 | Bubinga veneer Signature Series kit – 1982
- 09 | Horst Link Signature Series badge
- 10 | Signature HLD 590 bell bronze Snare Drum.
The heaviest Snare Drum ever – 15 kg / 33 lbs.
- 11 | First single strut completely adjustable
Single Bass Drum Pedal – 1980
- 12 | Designer Snare Drums – 1994
- 13 | First Custom Drum kit, Designer – 1994
- 14 | Giant Step Pedals – 2001

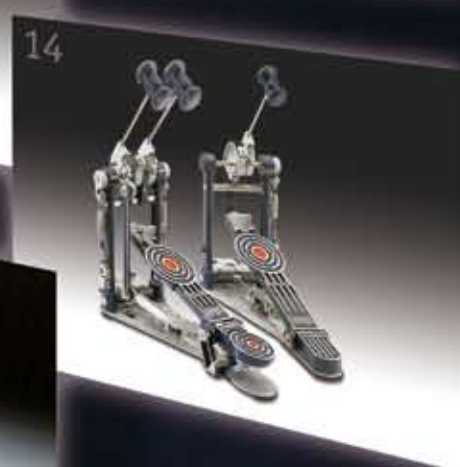
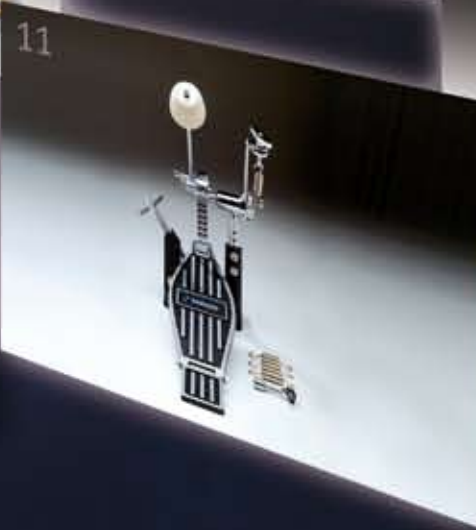

THE SQ² DISTINCTION

FEATURES & BENEFITS

TuneSafe – Right in Tune, 100% of the Time!

All Sonor lugs are equipped with the TuneSafe, which prevents tension rods from loosening even under the hardest hard rim shots or loosely tuned heads.

Select between square-headed tension rods, or our traditional slotted tension rods. Both versions utilize a fine-threading for precise optimum tuning.

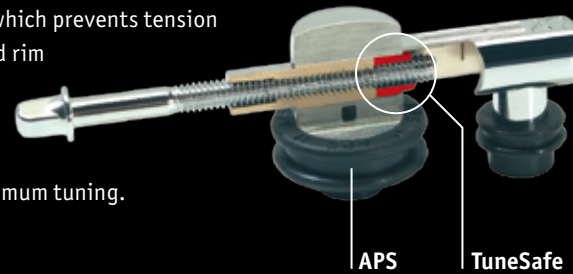

APS – Maximum Sustain

Special APS (Advanced Projection System) rubber insulators prevent direct contact between any metal parts and our shells. This gives our drums an extraordinarily dynamic, precise sustained tone.



T.A.R. – Extreme Resonance

T.A.R. (Total Acoustic Resonance) Tom Holder Systems freely suspends the toms to ensure incredible resonance and tone.



AcoustiGate – World's Only Adjustable Sustain System

Our AcoustiGate option on select T.A.R. Tom Mount Systems allows you to fine-tune the resonance and sustain of your Tom.

AcoustiGate



The T.A.R. Tom Holder with AcoustiGate and APS

SQ² Shell Hardware Patents

AcoustiGate
US Pat. 5.721.389 · JP Pat. 3506435
APS (Rubber bearing at the tom mount)
DE Pat. 43 02 134 · GB Pat. 2 274 735

TuneSafe
US Pat. 5.561.255

Shell with wave seam
US Pat. 5.330.848



SQ² Shells – The finest shells deserve the finest woods & acrylic

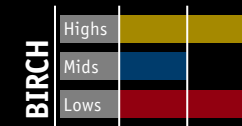

Scandinavian Birch has an aggressive, distinctive tone with tremendous projection. Providing low and high frequency clarity with a smooth balanced mid range.

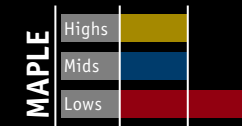

North American Maple offers a mellow, warm and very balanced full tone providing low frequency punch and a mixed balance of mids and highs.

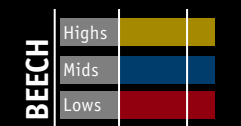

German Beech wood offers a full, warm tone with evenly balanced lows, mids and highs. Tremendous projection, tone and dynamics.

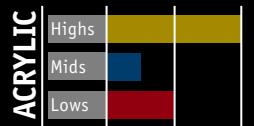

German Acrylic have a full-bodied tone with great presence and powerful dynamics. Accentuated highs and lows are more dominant with reduced mid range frequencies.

SQ² shell construction

Shell construction	Bass Drum / Gong Tom			Snare Drum / Tom Tom / Floor Tom		
	Plies	Veneer	Dynamic Edge	Plies	Veneer	Dynamic Edge
Vintage shell laquered	3 (6 mm)*		1 (2 mm)*	2 (4 mm)*		1 (2 mm)*
Vintage shell with outer veneer	2 (4 mm)*	1 (2 mm)*	1 (2 mm)*	1 (2 mm)*	1 (2 mm)*	1 (2 mm)*
Thin shell laquered	3 (6 mm)*			2 (4 mm)* + 1 (1 mm)*		
Thin shell with outer veneer	2 (4 mm)*	1 (2 mm)*		1 (2 mm)* + 1 (1 mm)*	1 (2 mm)*	
Thin shell with inner & outer veneer	1 (2 mm)*	2 (4 mm)*		1 (1 mm)*	2 (4 mm)*	
Medium shell laquered	3 (6 mm)*			3 (6 mm)*		
Medium shell with outer veneer	2 (4 mm)*	1 (2 mm)*		2 (4 mm)*	1 (2 mm)*	
Medium shell with inner & outer veneer	1 (2 mm)*	2 (4 mm)*		1 (2 mm)*	2 (4 mm)*	
Heavy shell laquered	4 (8 mm)*			4 (8 mm)*		
Heavy shell with outer veneer	3 (6 mm)*	1 (2 mm)*		3 (6 mm)*	1 (2 mm)*	
Heavy shell with inner & outer veneer	2 (4 mm)*	2 (4 mm)*		2 (4 mm)*	2 (4 mm)*	
Acrylic shell	1 (8 mm)*			1 (6 mm)*		

*) = rounded figures

SQ² shell hardware – Chrome, aranja or gold

Refine your SQ² kit with meticulously plated 24 k gold, chrome or aranja (black plated) drum hardware!

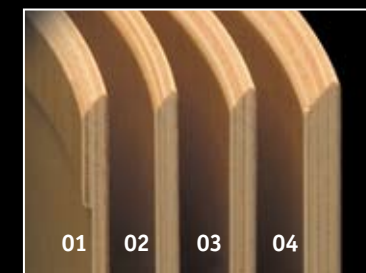

- 01 | Vintage shell*
- 02 | Thin shell
- 03 | Medium shell
- 04 | Heavy shell

*) = with Dynamic Edge (Reinforcement ring)

THE SQ² REVOLUTION

THE CONFIGURATOR SYSTEM



www.sq2-drumsystem.com

With the help of the SQ² Configurator, your custom dream drum kit is only a few clicks away! Visit www.sq2-drumsystem.com and immerse in the world of SQ²...

First click on the SQ² Configurator index and select your language preference and show prices for the country you reside.

You are now ready to click, create and customize your dream kit. Let Sonor make your dream a reality!



Drum		
Drum	Bass Drum, Snare Drum, Tom Tom, Floor Tom, Gong Tom	
Diameter	Depends on the chosen drum	160 different shell sizes
Depth	Depends on the chosen drum	
Green arrow > next		
Shell		
Shell material	Beech, Birch, Maple, X-Ray Acrylic	
Shell type	Vintage, Thin, Medium, Heavy	
Green arrow > next		

Shell surface		
Outside	Veneer, semi gloss	270 shell surfaces outside
	Veneer, high gloss	
	Veneer, semi gloss with fade	
	Veneer, high gloss with fade	
	Lacquer, high gloss	
	Lacquer, high gloss with fade	
	Sparkle, high gloss	
	Sparkle, high gloss with fade	
	RAL colors	
	Cover	
	Inside	
	Protective lacquer, semi gloss	
Green arrow > next		

Drum hoop for batter side		
Outside	Veneer, semi gloss	1.286 possible drum hoops
	Veneer, high gloss	
	Lacquer, high gloss	
	Sparkle, high gloss	
	RAL colors	
	Cover	
	X-Ray Acrylic	
Inside	Veneer, semi gloss	1.286 possible drum hoops
	Veneer, high gloss	
	Lacquer, high gloss	
	Sparkle, high gloss	
	RAL colors	
X-Ray Acrylic		
Green arrow > next		

Inside	Veneer, semi gloss	1.286 possible drum hoops
	Veneer, high gloss	
	Lacquer, high gloss	
	Sparkle, high gloss	
	RAL colors	
	X-Ray Acrylic	
	Green arrow > next	

Drum hoop for resonance side		
Outside	Veneer, semi gloss	1.286 possible drum hoops
	Veneer, high gloss	
	Lacquer, high gloss	
	Sparkle, high gloss	
	RAL colors	
	Cover	
	X-Ray Acryl	
Inside	Veneer, semi gloss	1.286 possible drum hoops
	Veneer, high gloss	
	Lacquer, high gloss	
	Sparkle, high gloss	
	RAL colors	
X-Ray Acrylic		
Green arrow > next		

Inside	Veneer, semi gloss	1.286 possible drum hoops
	Veneer, high gloss	
	Lacquer, high gloss	
	Sparkle, high gloss	
	RAL colors	
	X-Ray Acrylic	
	Green arrow > next	

Shell-Hardware		
Drum hoop 1 for batter side	Gold plated	
	Chrome	
	Black plated	
Die-cast hoop 1 for batter side	Gold plated	14" Snare Drums
	Chrome	14" Snare Drums
	Black plated	14" Snare Drums
Claw hooks 1 for batter side	Gold plated	
	Chrome	
	Black plated	
Tension rods 1 for batter side	Easy-grip rods, gold plated	Bass Drums
	Easy-grip rods, chrome	Bass Drums
	Easy-grip rods, black plated	Bass Drums
	Square-head rods, gold plated	
	Square-head rods, chrome	
	Square-head rods, black plated	
Lugs 1 for batter side	Slotted rods, gold plated	
	Slotted rods, chrome	
	Slotted rods, black plated	
	Gold plated	
Lugs 1 for batter side	Chrome	
	Black plated	



THE CONFIGURATOR SYSTEM



This example of an SQ² kit illustrates the vast number of possibilities our Configurator offers. SQ² allows you to meet nearly ALL your demands, dreams and wishes down to the tiniest detail! Such possibilities are unique to Sonor and redefine the parameters of what a customized kit can be.

Snare strainer	Gold plated
	Chrome
	Black plated
	No Snare strainer
Tom Tom holder	Gold plated
	Chrome
	Black plated
	No Tom Tom holder
Brackets	Gold plated
	Chrome
	Black plated
	No brackets
Bass Drum spurs	Gold plated
	Chrome
	Black plated
	No Bass Drum spurs
SQ2 Logo	Gold plated
	Chrome
	Black plated
	No SQ2 Logo
Snare wires	Depends on the shell size 22 Snare wires
	No Snare wires

Floor Tom legs	Gold plated	
	Chrome	
	Black plated	
	No Floor Tom legs	
Bass Drum mount	BD mounting plate, gold plated	
	BD mounting plate, chrome	
	BD mounting plate, black plated	
	BD mount, gold plated	
	BD mount, chrome	
	BD mount, black plated	
	No Bass Drum mount	
Drum hoop 2 for resonance side	Gold plated	
	Chrome	
	Black plated	
	No Drum hoop for resonance side*	
Die-cast hoop 2 for resonance side	Gold plated	14" Snare Drums
	Chrome	14" Snare Drums
	Black plated	14" Snare Drums
	No Die-cast hoop for resonance side*	
Claw hooks 2 for resonance side	Gold plated	
	Chrome	
	Black plated	
	No claw hooks	

Lugs 2 for resonance side	Gold plated	
	Chrome	
	Black plated	
	No Lugs*	
Tension rods 2 for resonance side	Easy-grip rods, gold plated	Bass Drums
	Easy-grip rods, chrome	Bass Drums
	Easy-grip rods, black plated	Bass Drums
	Square-head rods, gold plated	
	Square-head rods, chrome	
	Square-head rods, black plated	
	Slotted rods, gold plated	
	Slotted rods, chrome	
Slotted rods, black plated		
No Tension rods*		
Green arrow ► next		

Drum heads		
Batter head	Depends on the chosen drum	13 different heads
Resonance head	Depends on the chosen drum	13 different heads
Green arrow ► Basket		

After creating your ultimate drum kit, be sure to include hardware by selecting the Hardware Configurator from the index in the SQ² Configurator index of contents. Choose hardware from our Giant Step, 600 or 400** series components to support, expand and elevate the level of performance as well as function of your SQ² kit!

After you completed and saved your SQ² kit and hardware please click the print button. Now you can see your customized SQ² instrument on the printed sheet together with your individual UPID (Unique Print Identification) number. When you are ready to order, simply submit your UPID number to your local authorized Sonor Dealer (a list of authorized dealers can be found in the SQ² Configurator index of contents). As soon as we receive your order from your chosen local dealer, your individual UPID number will be transferred into our database system and forwarded onto the production department!

The SQ² Evolution

Sonor continues to update and expand its Configurator with more language options, new instruments, extra limited specials, veneers and finishes.

Visit www.sq2-drumsystem.com regularly for an ever-changing new and updated experience in drum design.

*) does not apply to Tom Toms (because of the H-Bar T.A.R.)

**) 400 Series Hardware is not available in all countries.

Black
**BLACK & WHITE
BEAUTY**

SQ² Set – Solid White

> UPID 119643126797-1

Shell material: Birch
 Shell construction: Thin
 Finish outside: Solid White, high gloss
 Drum hoop: Solid Black, high gloss
 Shell Hardware: Black plated
Bass Drum 16" x 18"
Snare Drum 14" x 4.25"
Tom Tom 10" x 8"
Floor Tom 14" x 13"

> **Hardware 600 & Basic Arm (BA)**

CBS 672 Cymbal Boom Stand
MBS 673 Mini Boom Stand with
BA12-BR BA 12 – Basic Ratchet (3x)
BA-CH BA – Cymbal Holder (2x)
BA-PA BA – Percussion Adapter

MBS 673 Mini Boom Stand with
BA-BC BA – Basic Clamp (2x)
BA19-BR BA 19 – Basic Ratchet
BA19-M Basic Arm 19, medium
XH 674 X-Hat
SS 677 Snare Drum Stand
HH 684 Two-Leg Hi-Hat Stand
CTS 679 Cymbal Tom Stand with
BA19-BR BA 19 – Basic Ratchet (2x)
BA19-S Basic Arm 19, short
BA-PA BA – Percussion Adapter
MBS 673 Mini Boom Stand with
BA12-BR BA 12 – Basic Ratchet
BA-CH BA – Cymbal Holder
 > **Giant Step**
GMP 4 Giant Middle Pedal

Dreams
WALNUT DREAMS

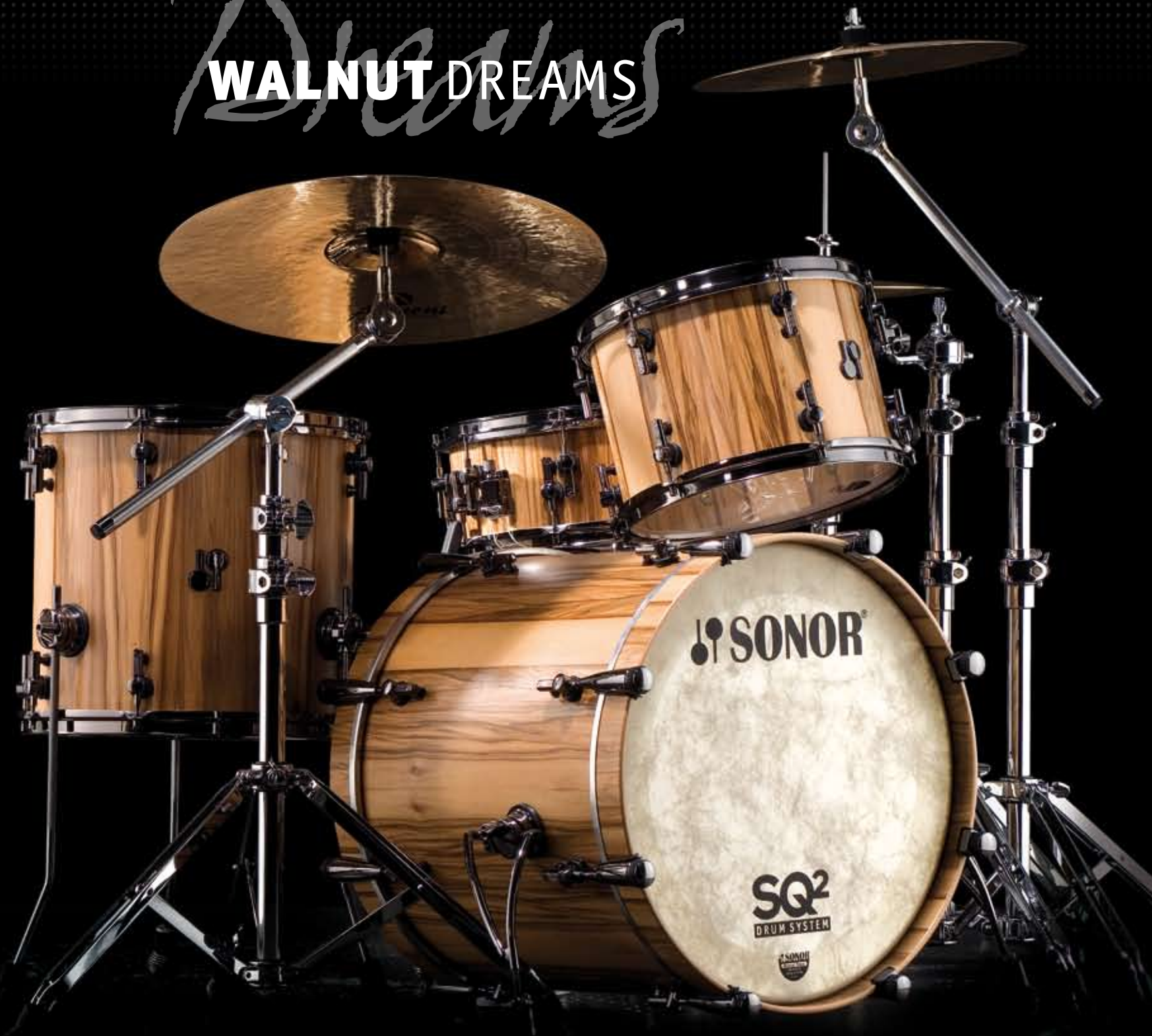

SQ² Set – American Walnut

> UPID 119643119422-1

Shell material: Beech

Shell construction: Heavy

Veneer outside: American Walnut, semi gloss

Veneer inside: American Walnut, semi gloss

Shell Hardware: Black plated

Bass Drum 20" x 18"

Snare Drum 13" x 6"

Tom Tom 13" x 9"

Floor Tom 15" x 14"

> **Hardware 600**

CBS 672 Cymbal Boom Stand (2x)

SP 673 Bass Drum Single Pedal

DT 680 Drummer's Throne

SS 677 Snare Drum Stand

HH 674 Hi-Hat Stand

STS 676 Single Tom Stand

GOLDEN PEARL



SQ² Set – Red Pearl

> UPID 119643238748-1

Shell material: Beech
 Shell construction: Vintage
 Veneer outside: Red Pearl, Cover
 Shell Hardware: Gold plated
Bass Drum 24" x 19"
Snare Drum 14" x 7"
Tom Tom 14" x 13"
Floor Tom 16" x 15"
Floor Tom 18" x 17"
Gong Tom 18" x 15"

> **Hardware 600 & Basic Arm (BA)**

CBS 672 Cymbal Boom Stand mit
BA19-BR BA 19 – Basic Ratchet (2x)
BA19-L Basic Arm 19, long
BA-BC BA – Basic Clamp

BA19-S Basic Arm 19, short
BA-PA BA – Percussion Adapter
BA19-BDS BA 19 – Basic Double Stand with
BA19-S Basic Arm 19, short (2x)
BA-TB BA – Tele Boom Arm (2x)
BA-CH BA – Cymbal Holder (2x)
CBS 672 Cymbal Boom Stand(2x)
SP 673 Bass Drum Single Pedal
DT 670 Drummer's Throne
SS 677 Snare Drum Stand (2x)
HH 674 Hi-Hat Stand
STS 676 Single Tom Stand (2x)
CBS 672 Cymbal Boom Stand with
BA19-BR BA 19 – Basic Ratchet
BA19-L Basic Arm 19, long

Tiger
THE TIGER WITHIN



SQ² Set – Stratawood

> UPID 119643404683-1

Shell material:	Birch
Shell construction:	Heavy
Veneer outside:	Stratawood, high gloss
Veneer inside:	Tiger Finish, semi gloss
Shell Hardware:	Chrome
Bass Drum	22" x 20"
Snare Drum	14" x 5.5"
Tom Tom	8" x 7"
Tom Tom	10" x 7"
Tom Tom	12" x 7"
Floor Tom	14" x 12"
Floor Tom	16" x 12"

>	Hardware 600 & Basic Arm (BA)
MBS 673	Mini Boom Stand (3x)
DT 670	Drummer's Throne
DTH 675	Double Tom Holder
SS 677	Snare Drum Stand
BA19-BDS	BA 19 – Basic Double Stand with
BR12	Basic Rack 12
BA12-BR	BA 12 – Basic Ratchet
BA-CH	BA – Cymbal Holder
TA 678	Tom Arm with ball clamp
HH 684	Two-Leg Hi-Hat Stand
>	Giant Step
GTRP 3	Giant Triple Pedal

Blaster

INTERGALACTIC METAL BLASTER

SQ² Set – Black-Red Sparkle

> UPID 119643521046-1

Shell material: Maple

Shell construction: Medium

Finish outside: Black-Red Sparkle, high gloss

Shell Hardware: Chrome

Bass Drum 24" x 18"

Bass Drum 22" x 18"

Snare Drum 13" x 8"

Tom Tom 10" x 10"

Tom Tom 12" x 12"

Floor Tom 14" x 16"

Floor Tom 16" x 18"

> Hardware 600 & Basic Arm (BA)

CBS 672 Cymbal Boom Stand (2x)

CBS 672 Cymbal Boom Stand mit

BA19-BR BA 19 – Basic Ratchet (3x)

BA19-L Basic Arm 19, long (2x)

BA-BC BA – Basic Clamp (2x)

BA19-S Basic Arm 19, short

XH 674 X-Hat

BA19-BDA BA 19 – Bass Drum Adapter with

BA19-S Basic Arm 19, short

BA19-BR BA 19 – Basic Ratchet

BA-PA BA – Percussion Adapter

DT 680 Drummer's Throne

SS 677 Snare Drum Stand

DTS 675 Double Tom Stand

BA19-BDS BA 19 – Basic Double Stand with

BA19-S Basic Arm 19, short (2x)

BA-TB BA – Tele Boom Arm (2x)

BA-CH BA – Cymbal Holder (2x)

HH 684 Two-Leg Hi-Hat with

BA19-BDA BA 19 – Bass Drum Adapter

BA-CR BA – Connection Ratchet

BA19-BR BA 19 – Basic Ratchet

BA19-M Basic Arm 19, medium

BA-BC BA – Basic Clamp

CBS 672 Cymbal Boom Stand with

BA19-BR BA 19 – Basic Ratchet

BA19-L Basic Arm 19, long

MBS 673 Mini Boom Stand with

BA12-BR BA 12 – Basic Ratchet (3x)

BA-CH BA – Cymbal Holder (3x)

> Giant Step

GSP 3 Giant Single Pedal (2x)

Woble
JUST NOBLE

SQ² Set – Walnut Roots

> UPID 119644005960-1

Shell material:	Maple
Shell construction:	Medium
Veneer outside:	Walnut Roots, high gloss
Shell Hardware:	Gold plated
Bass Drum	22" x 18"
Snare Drum	14" x 5"
Tom Tom	8" x 7"
Tom Tom	10" x 8"
Tom Tom	12" x 9"
Floor Tom	14" x 14"
Floor Tom	16" x 16"

> **Hardware 600 & Basic Arm (BA)**

CBS 672	Cymbal Boom Stand (4x)
BA19-BDS	BA 19 – Basic Double Stand with
BA19-S	Basic Arm 19, short

BA19-BR	BA 19 – Basic Ratchet
BA19-L	Basic Arm 19, long
BA-CH	BA – Cymbal Holder
TA 678	Tom Arm with ball clamp
SP 673	Bass Drum Single Pedal
DT 680	Drummer's Throne
SS 677	Snare Drum Stand
DTS 675	Double Tom Stand
HH 674	Hi-Hat Stand

> *additionally shown at the backview:*

CBS 672	Cymbal Boom Stand with
BA19-BR	BA 19 – Basic Ratchet
BA-PA	BA – Percussion Adapter
BA19-BSS	BA 19 – Basic Single Stand with
BA19-S	Basic Arm 19, short
BA-TA	BA – Tom Arm

THE SQ² HARDWARE GIANT STEP SERIES

Giant Step Patents

Docking Station
US Pat. 6.632.990 · EU Pat. 1 237 146

Rotation Pendulum
EU Pat. 1 237 147

Splitboard
US Pat. 6.417.433 · EU Pat. 0 986 806
JP Pat. 4035172

Twin Effect Pedal
US Pat. 6.649.820 · EU Pat. 1 237 145

Maximum speed and power

The Sonor Giant Step Bass Drum Pedals are the perfect tool for demanding drummers unwilling to sacrifice any of their musical freedom and demand only the best. The state-of-the-art design delivers optimum feel, control, speed and power. Giant Step's engineering and design allows for maximum adjustability elevating Giant Step into a class of its own.



Smart Connect System –

The Flexible Pedal Attachment

The "Smart Connect" System ensures a quick and effortless attachment of the pedal with an adjustable ball clamp through a firm lever mechanism. A cylindrical axle connection neutralizes any possible tensions through different bass drum angle positions.



Docking Station –

Installation is Child's Play

The docking station is mounted to the bass drum hoop and stays there.



All Giant Step pedals are equipped with a chain drive. An exchangeable strap is included as well.

As an option, straps, chains, springs, and beaters are also available.



Giant Step Bass Drum Pedals

GSP 3	Giant Step Single Pedal
GTEP 3	Giant Step Twin Effect Pedal
GDPR 3	Giant Step Double Pedal, right
GDPL 3	Giant Step Double Pedal, left
GTRP 3	Giant Step Triple Pedal
GMP 4	Giant Step Middle Pedal
GSDS	Giant Step Docking Station
GPB	Giant Step Bag
GSC	Giant Step Silent Chain
GSS	Giant Step Silent Strap (not shown)
GSR	Giant Step Spring Tension Adjustment, regular (not shown)
GSH	Giant Step Spring Tension Adjustment, heavy (not shown)



GTEP 3 Twin Effect Pedal



GTRP 3 Triple Pedal



GDPL 3 Double Pedal, left



GDPR 3 Double Pedal, right



GSP 3 Single Pedal

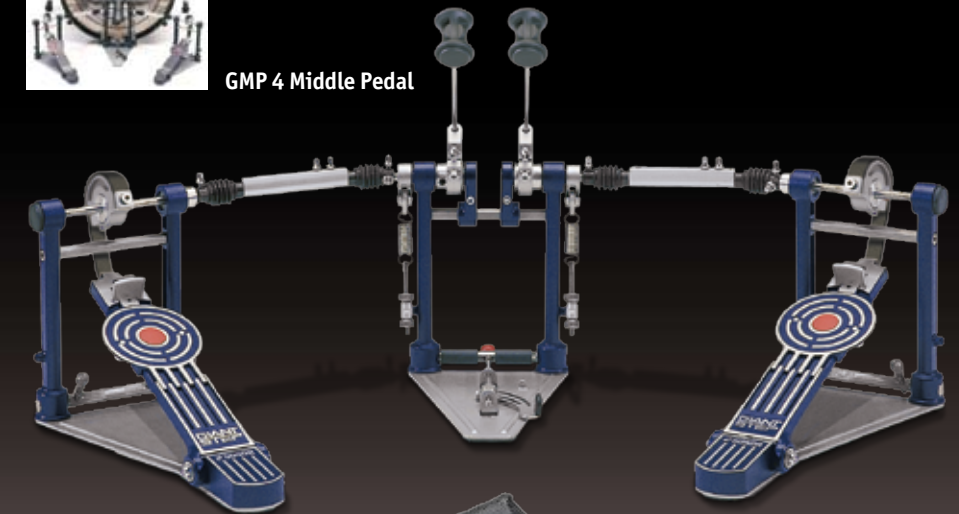

GMP 4 Middle Pedal



Giant Step Bag –

Complete Safe Transport

All Giant Step Pedals are supplied standard with a heavy duty nylon carrying bag.

THE SQ² HARDWARE HARDWARE 600 SERIES

600 Series Hardware is the pinnacle of the Sonor hardware. All components allow for maximum flexibility, professional features, attention to detail and versatility you expect from over 130 years of German Engineering and design!

Hardware 600 Patents

3-Section Clamp
DE Pat. 102 57 515

Adjustable Leg
DE Pat. 44 00 151 · JP Pat. 2 564 110
US Pat. 5,509,629

Ball Clamp AX-6
DE Pat. 43 33 913 · GB Pat. 2 273 043
US Pat. 5,803,642

4-Section Clamp
US Pat. 5,803,642 · DE Pat. 43 33 913
GB Pat. 2 273 043

3-Section Clamp – Enormous Support for Very Little Effort

The 3-section clamp can spread the force around three sides of a stand rod in a way that no other clamp can. This means it can be secured with just a small amount of effort.

Adjustable Leg – Adjusts to Fit Every Configuration

The independently adjustable base leg of the hardware 600 suits a drummer's own individual set-up.

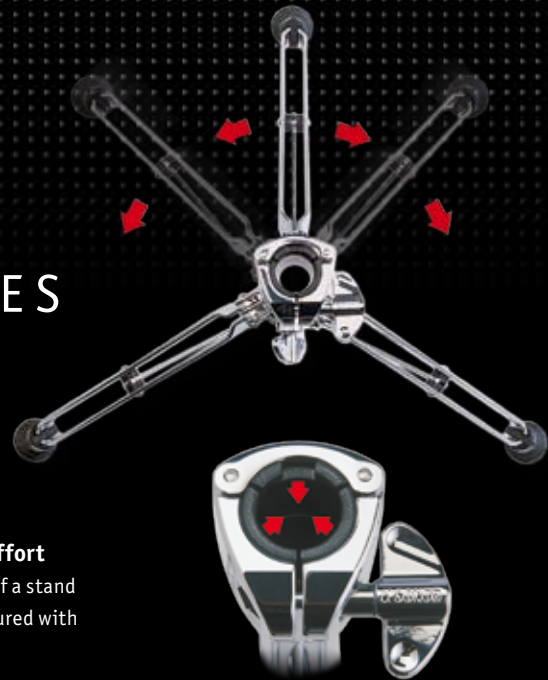

- DTS 675** Double Tom Stand,
2 tom arms with ball clamp
- STS 676** Single Tom Stand
with tom arm with ball clamp
- CTS 679** Cymbal Tom Stand
with tom arm with ball clamp
and cymbal boom arm
- DCS 678** Double Cymbal Stand
with two cymbal boom arms
- HH 674** Hi-Hat Stand (see HH 684)
- HH 684** Two-Leg Hi-Hat Stand
with adjustable spring tension,
swivel foot board, retractable,
with toe stop, 7-step bottom
cymbal tilter, legs convertible
from rubber to metal spurs

- SS 677** Snare Drum Stand
with quick release lever
- DT 670** Drummer's Throne,
round seat, with spindle,
with Drum Key holder
- DT 680** Drummer's Throne,
saddle seat, with spindle,
with Drum Key Holder
- XH 674** X-Hat
with adjustable spring tension,
7-step bottom cymbal tilter
- STH 674** Single Tom Holder
with 3-section clamp and
tom arm with ball clamp
- DTH 675** Double Tom Holder
with 2 tom arms with ball clamp

- CBS 672** Cymbal Boom Stand,
400 mms boom arm length,
360° rotation
- MBS 673** Mini Boom Stand
with retractable boom arm
- CBA 671** Cymbal Boom Arm,
400 mms boom arm length,
360° rotation
- TA 678** Tom Arm with ball clamp
- MC 676** Multi Clamp



7-step, very easy to operate cymbal tilter



Quick Release Lever - Couldn't Be Easier!
No more complicated screwing in place ever again. Simply lay the snare drum on the stand – flip the lever – and that's it.

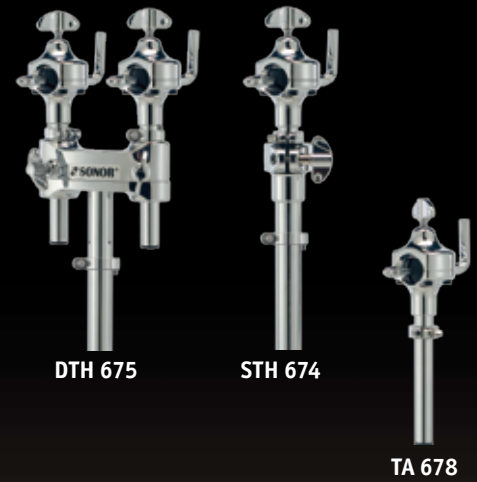

THE SQ² HARDWARE BASIC ARM SYSTEM

Freedom, flexibility, function

The Basic Arm System utilizes a vast array of arms, ratchets and adapters to create the ultimate in flexibility, form and function, allowing you to create your own customized individual hardware setup.

The Basic Arm System is divided into the Basic Arm 19 and Basic Arm 12, reflecting the variation in tube diameters. We utilize identical ratchets overall for ease of compatibility between the components.

The details are too many to mention, look at the following practical examples or experiment and design the Basic Arm System of your own.

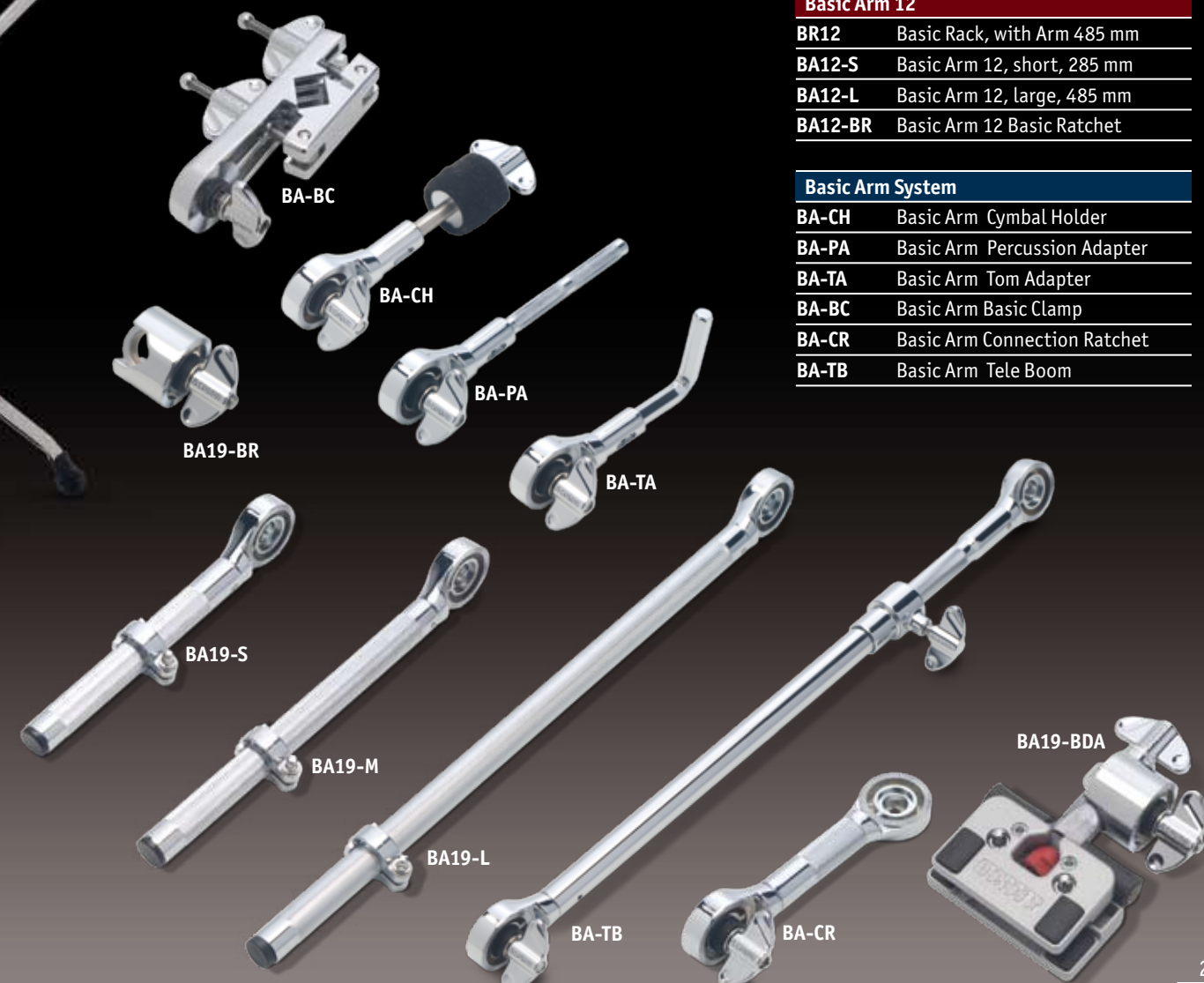

Basic Arm 19	
BA19-S	Basic Arm 19, short, 150 mm
BA19-M	Basic Arm 19, medium, 220 mm
BA19-L	Basic Arm 19, large, 400 mm
BA19-BR	Basic Arm 19 Basic Ratchet
BA19-BDA	Basic Arm 19 Bass Drum Adapter
BA19-BSS	Basic Arm 19 Single Stand
BA19-BDS	Basic Arm 19 Double Stand

Basic Arm 12	
BR12	Basic Rack, with Arm 485 mm
BA12-S	Basic Arm 12, short, 285 mm
BA12-L	Basic Arm 12, large, 485 mm
BA12-BR	Basic Arm 12 Basic Ratchet

Basic Arm System	
BA-CH	Basic Arm Cymbal Holder
BA-PA	Basic Arm Percussion Adapter
BA-TA	Basic Arm Tom Adapter
BA-BC	Basic Arm Basic Clamp
BA-CR	Basic Arm Connection Ratchet
BA-TB	Basic Arm Tele Boom

DIE SQ² HARDWARE BASIC ARM SYSTEM



BA-BC, BA19-CR, BA12-BR (3x),
BA12-L, BA-CH, BA-PA



BR12, BA12-BR (5x), BA-CH (3x),
BA-PA (2x)



BA19-BDS, BA19-S (2x), BA-TB (2x)



BA-BC, BA19-BR, BA19-M, BA19-BR,
BA19-L, BA-CH



BA-BC, BA19-BR, BA19-S, BA19-BR,
BA19-M, BA-BC



BA-BC, BA19-BR, BA19-S, BA19-BR,
BA19-M, BA-TA



BA 19-BSS, BA19-S, BA19-BR, BA19-M,
BA-BC



BA-BC, BA19-BR, BA19-BR, BA19-M,
BA-BC

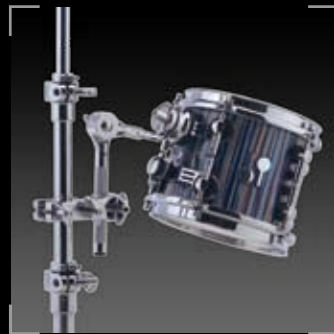

BA-BC, BA19-S, BA-TA



BA-BC, BA-PA



BA19-BDA, BA-CR, BA19-BR,
BA19-S, BA-BC



BA19-BSS, BA19-S, BA19-BR,
BA19-S, BA-TA



BA19-BSS, BA19-S, BA19-BR,
BA19-S, BA-PA



BA19-BDA, BA-PA



BA19-BDA, BA19-S, BA19-BR, BA-PA



BA19-BDA, BA19-CR, BA-PA



BA19-BSS, BA19-S, BA-TA



BA19-BSS, BA19-S, BA19-BR,
BA19-S, BA-TA



BA19-BSS, BA19-S, BA19-BR,
BA19-S, BA-PA



CBS 672 Cymbal Boom Stand with
BA19-BR, BA19-L



Easy and clever:
Depending on the combination of our
Basic Arm components simply remove
a guide ring.



Simply combine and assemble our
Basic Arm components.



BA19-BR